

SITE PLAN FOR 9153 DOVE LN. (S/L 9) - MENTOR, OH

DISCLAIMER:

BUILDER AND ALL SUBCONTRACTORS SHALL REVIEW THIS PLAN TO VERIFY HOUSE DIMENSIONS AND ALL SITE IMPROVEMENTS FOR ANY DISCREPANCIES, OMISSIONS AND/OR CHANGES AND NOTIFY BARRINGTON CONSULTING GROUP, INC. PRIOR TO ANY SITE WORK.

BARRINGTON CONSULTING GROUP, INC. HAS NOT CONDUCTED A WETLANDS OR TITLE SEARCH INVESTIGATION OR RESEARCHED ANY RECORDS TO DETERMINE IF ANY WETLANDS OR EASEMENTS ARE PRESENT ON THIS SITE. ANY WETLAND OR EASEMENT INFORMATION SHOWN ON THIS PLAN IS NOT GUARANTEED TO BE COMPLETE OR ACCURATE. THE OWNER IS RESPONSIBLE TO TAKE THE APPROPRIATE STEPS WITH REGARD TO ANY WETLANDS OR EASEMENTS THAT MIGHT BE PRESENT ON THIS SITE OR ADJACENT TO THIS SITE PRIOR TO THE START OF ANY ACTIVITY ON THE LOT.

THIS PLAN HAS BEEN PREPARED SOLELY FOR THE PURPOSE OF ESTABLISHING GRADING, DRAINAGE, LOCATION OF UTILITY CONNECTIONS, AND COMPLIANCE WITH LOCAL ZONING REGULATIONS AND IS BASED UPON PLANS APPROVED BY AGENCIES HAVING JURISDICTION. BARRINGTON CONSULTING GROUP, INC. DOES NOT WARRANT OR GUARANTEE STRUCTURAL COMPONENTS OF THE STRUCTURE(S) OR THE UNDERLYING SOILS OR SUBSURFACE CONDITION(S) THAT MAY OR MAY NOT EXIST.

GENERAL NOTES:











CONTRACTOR RESPONSIBLE FOR CONTACTING THE OHIO UTILITY PROTECTION SERVICE (1.800.362.2764) AND ALL UTILITY COMPANIES A MINIMUM OF 48 HOURS PRIOR TO CONSTRUCTION.

THE LOCATION BOTH HORIZONTAL AND VERTICAL OF EXISTING UNDERGROUND UTILITIES SHOWN HEREON, HAVE BEEN OBTAINED BY A DILIGENT AND COMPREHENSIVE SEARCH OF AVAILABLE RECORDS. VERIFICATION BY FIELD OBSERVATION HAS BEEN CONDUCTED WHERE PRACTICAL, HOWEVER, BARRINGTON CONSULTING GROUP, INC. DOES NOT GUARANTEE THE COMPLETENESS, NOR ACCURACY THEREOF.

CONTRACTOR SHALL VERIFY ELEVATIONS OF LATERAL INVERTS IN THE FIELD PRIOR TO FOUNDATION EXCAVATION.

PRIOR TO ANY WORK BEING PERFORMED WITHIN THE RIGHT OF WAY AND/OR UNDERGROUND UTILITY EASEMENTS, CONTRACTOR SHALL CONFIRM THAT ALL REQUIRED CLEARANCES AND BURY DEPTHS OF ALL UNDERGROUND UTILITIES WILL BE MAINTAINED AS A RESULT OF ANY AND ALL SITE IMPROVEMENTS.

SITE PLAN LEGEND

| | | | |
|---|--------------------------|---|------------------------|
|  | TRAFFIC DIRECTION |  | EXISTING MAJOR CONTOUR |
|  | OVERLAND FLOW |  | EXISTING MINOR CONTOUR |
|  | EROSION CONTROL NOTE |  | PROPOSED MAJOR CONTOUR |
|  | SILT FENCE / FILTER SOCK |  | PROPOSED MINOR CONTOUR |
|  | SOIL BOUNDARY |  | LIMITS OF DISTURBANCE |

EROSION & SEDIMENT CONTROL (E&SC) SCHEDULE:

INGRESS-EGRESS: A STONE ACCESS DRIVE COMPLETE WITH UNDER LYING GEO-TEXTILE FABRIC (14 FEET WIDE AND 30 FEET LONG) FOR INGRESS AND EGRESS AT THE SITE SHALL BE INSTALLED. THIS DRIVE SHALL BE THE ONLY ENTRANCE AND EXIT TO THE SITE.

STREETS DIRECTLY ADJACENT TO THE CONSTRUCTION ENTRANCES AND RECEIVING TRAFFIC FROM THE DEVELOPMENT AREA, SHALL BE CLEANED DAILY TO REMOVE SEDIMENT TRACKED OFF-SITE. IF APPLICABLE, THE CATCH BASINS ON THESE STREETS NEAREST TO THE CONSTRUCTION ENTRANCES SHALL BE CLEANED WEEKLY.

SILT FENCE / FILTER SOCK: ALL SILT FENCE / FILTER SOCK SHALL BE INSTALLED PRIOR TO ANY EARTHWORK ACTIVITIES AT THE SITE IN THE LOCATIONS SHOWN ON THE SITE PLAN AS WELL AS ALONG THE FRONT OF ANY LOT THAT SLOPES TOWARDS THE STREET.

TEMPORARY SEEDING: DISTURBED AREAS OF THE SITE THAT ARE TO REMAIN IDLE FOR MORE THAN FOURTEEN (14) DAYS SHALL BE PROPERLY SEEDED AND STRAW MULCHED WITHIN SEVEN (7) DAYS OF COMPLETION OF INITIAL GRADING. TEMPORARY SEEDING AND MULCHING OF A THIRTY (30) FOOT STRIP OF THE ENTIRE FRONT OF THE LOT SHALL BE MAINTAINED ON THE SITE ONCE INITIAL GRADING IS COMPLETE.

STABILIZATION OF CRITICAL AREAS WITHIN FIFTY (50) FEET OF ANY STREAM OR WETLAND SHALL BE COMPLETE WITHIN TWO (2) DAYS OF THE DISTURBANCE IF THE SITE IS TO REMAIN INACTIVE FOR LONGER THAN FOURTEEN (14) DAYS.

MULCHING: STRAW-MULCH SHALL BE APPLIED AT A RATE OF 1 BALE PER EVERY TEN (10) FEET OF CURB, AT A WIDTH OF THIRTY (30) FEET OF THE ENTIRE LENGTH OF THE LOT. WOOD CHIPS MAY ALSO BE USED BUT MUST BE SPREAD AT A MINIMUM DEPTH OF FOUR INCHES OVER THE THIRTY-FOOT WIDTH AND MUST BE ACCOMPANIED BY A PROPERLY INSTALLED SILT FENCE.

MAINTENANCE: EROSION AND SEDIMENT CONTROLS SHALL BE INSPECTED EVERY SEVEN (7) DAYS OR WITHIN 24 HOURS OF A 0.5" OR GREATER RAINFALL EVENT. NECESSARY REPAIRS SHALL BE MADE AT THIS TIME.

NOTE: ALL EROSION AND SEDIMENT CONTROL SPECIFICATIONS, APPLICATIONS, AND TIMETABLES ARE BASED OF THE DESCRIPTIONS AND STANDARDS OF THE OHIO DEPARTMENT OF NATURAL RESOURCES "RAINWATER AND LAND DEVELOPMENT MANUAL".

THE SPECIFIED EROSION AND SEDIMENT CONTROL STANDARDS ARE GENERAL GUIDELINES AND SHALL NOT LIMIT THE RIGHT OF THE COUNTY TO IMPOSE, AT ANY TIME, ADDITIONAL, MORE STRINGENT REQUIREMENTS. NOR SHALL THE STANDARDS LIMIT THE RIGHT OF THE COUNTY TO WAIVE, IN WRITING, INDIVIDUAL REQUIREMENTS.

OHIO UTILITIES PROTECTION SERVICE

CALL: 800-362-2764 OR 811 NON-MEMBERS MUST BE CONTACTED DIRECTLY



THE LOCATION BOTH HORIZONTAL AND VERTICAL OF THE EXISTING UNDERGROUND UTILITIES SHOWN HEREON, HAVE BEEN OBTAINED BY A DILIGENT AND COMPREHENSIVE SEARCH OF AVAILABLE RECORDS. VERIFICATION BY FIELD OBSERVATION HAS BEEN CONDUCTED WHERE PRACTICAL, HOWEVER, BARRINGTON CONSULTING GROUP, INC. DOES NOT GUARANTEE THE COMPLETENESS, NOR ACCURACY THEREOF.

SITE NOTES:

1. BENCHMARK LOCATED AS SHOWN = TOP STEM OF FIRE HYDRANT BENCHMARK ELEVATION = 628.09
2. FOR ESC PLAN SEE SHEET 5 AND FOR SEEDING INFORMATION SEE SHEET 2
3. ALL DOWNSPOUTS SHALL BE OUTLETTED TO SPLASH BLOCKS
4. CONCRETE SIDEWALK SHALL BE FIVE FEET WIDE AND FOUR INCHES THICK
 - 4.1. SIDEWALK SHALL BE SIX INCHES THICK AT DRIVEWAY APRON
5. SUMP PUMP REQUIRED FOR BASEMENT
6. A COVERED DUMPSTER FOR THE PROPER DISPOSAL OF CONSTRUCTION SITE WASTE MATERIALS SHALL BE PROVIDED BY OWNER
7. AN AS-BUILT DRAWING INDICATING FOUNDATION ELEVATION WILL BE REQUIRED AFTER FOUNDATION OR SLAB INSPECTION AND PRIOR TO FRAMING OF THE STRUCTURE
8. BASEMENT FINISH FLOOR ELEVATION SHALL BE A MINIMUM OF 16 INCHES ABOVE GROUND WATER ELEVATION. ANY ELEVATION ADJUSTMENT DUE TO THE EXISTING SITE CONDITIONS SHALL BE REVIEWED BY THE CHIEF BUILDING OFFICIAL PRIOR TO CONTINUING CONSTRUCTION.

OWNER

LITTLE MOUNTAIN HOMES, INC.
 RICK COLWELL
 1447 NORTH RIDGE ROAD
 PAINESVILLE, OHIO 44077
 PH: 440-357-8459

CERTIFICATION:

I THE UNDERSIGNED HEREBY CERTIFY THAT THIS TOPOGRAPHY INDICATED BY 1 FOOT CONTOURS AND ELEVATION SHOWN HEREON REPRESENTS AN ACTUAL SURVEY UNDER MY SUPERVISION ON THE 29th DAY OF MARCH, 2024 AND THE ELEVATIONS WERE TAKEN AT APPROPRIATE INTERVALS AND AS OF THAT DAY THEY EXISTED AS INDICATED HEREON. ADDITIONAL TOPOGRAPHICAL INFORMATION SHOWN HEREON LOCATED IN INACCESSIBLE AREAS, HEAVILY WOODED AREAS, OR AREAS OUTSIDE OF THE PROJECT AREA MAY HAVE BEEN OBTAINED FROM A GEOGRAPHIC INFORMATION SYSTEM WEBSITE OR OTHER SOURCES.



DAVID W. NOVAK

OHIO PROFESSIONAL SURVEYOR NO. 7507

January 9, 2025

24003-009

| | | | | | | | |
|------|----|-----------|--|--|--|--|--|
| DATE | BY | REVISIONS | | | | | |
| | | | | | | | |

Barrington
 CONSULTING GROUP, INC.
 9114 TYLER BLVD., MENTOR, OHIO 44060
 PHONE 440.205.1260
 www.BarringtonCGI.com

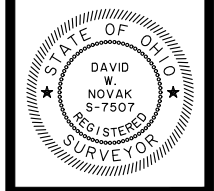

TITLE SHEET

9153 DOVE LN., MENTOR, OHIO 44060
 S/L 9 GLENBROOK ESTATES SUBDIVISION VOL. 72 PG. 30

LITTLE MOUNTAIN HOMES, INC.

DRAWN WSO

CHECKED DWN

DATE 1/7/25

SCALE NONE

JOB NO. 24003-009

SHEET



| | |
|-----------|--|
| BY | |
| REVISIONS | |
| DATE | |

Barrington
CONSULTING GROUP, INC.
9114 TYLER BLVD., MENTOR, OHIO 44060
PHONE 440.215.1260
www.BarringtonCGI.com



DETAILS
9153 DOVE LN., MENTOR, OHIO 44060
S/L 9 GLENBROOK ESTATES SUBDIVISION VOL. 72 PG. 30
LITTLE MOUNTAIN HOME, INC.

| | |
|---------|-----------|
| DRAWN | WSO |
| CHECKED | DWN |
| DATE | 1/7/25 |
| SCALE | NONE |
| JOB NO. | 24003-009 |
| SHEET | |

2

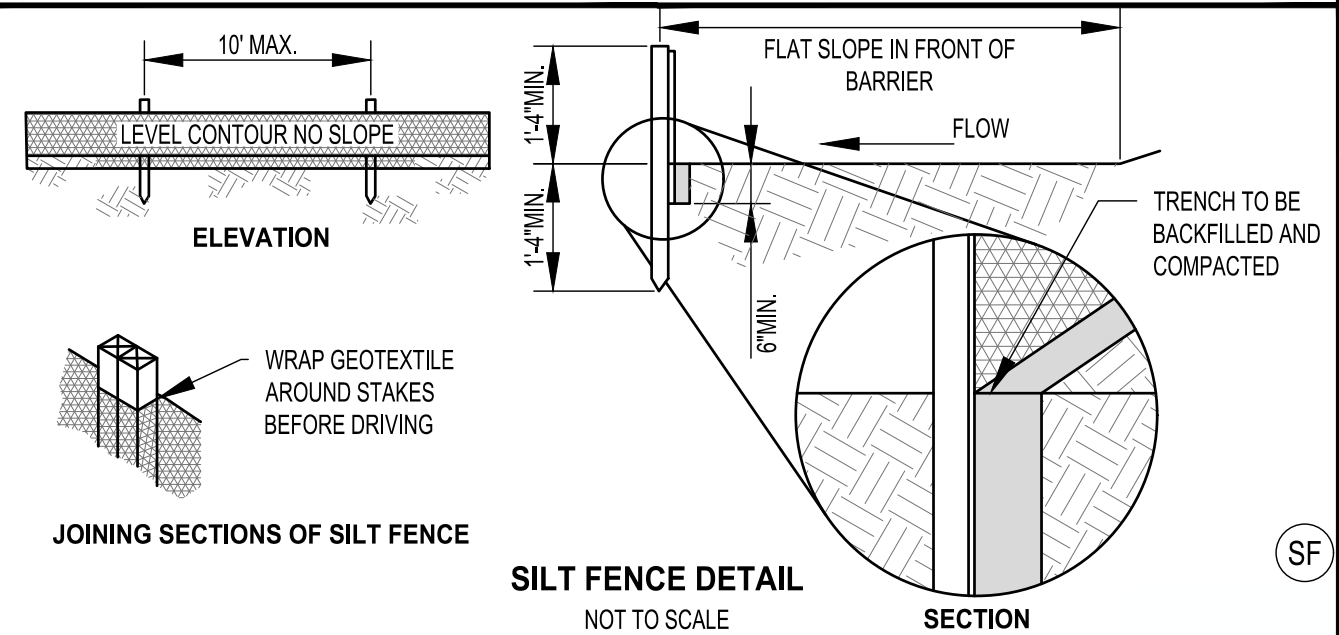
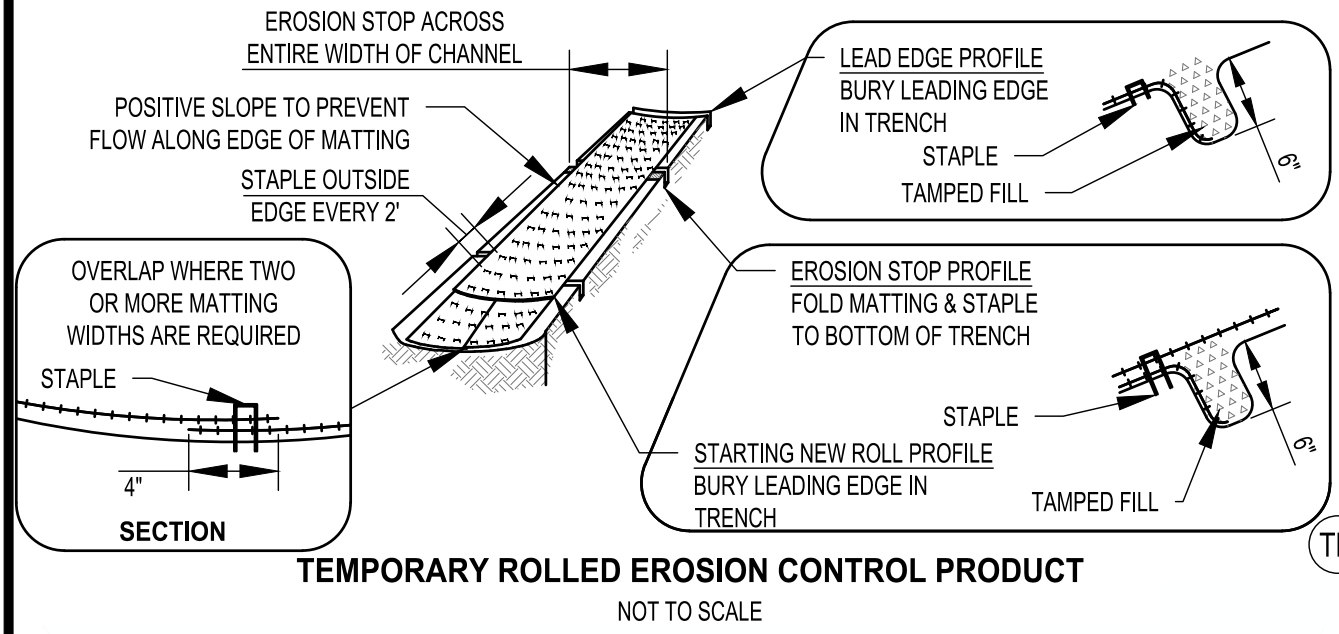
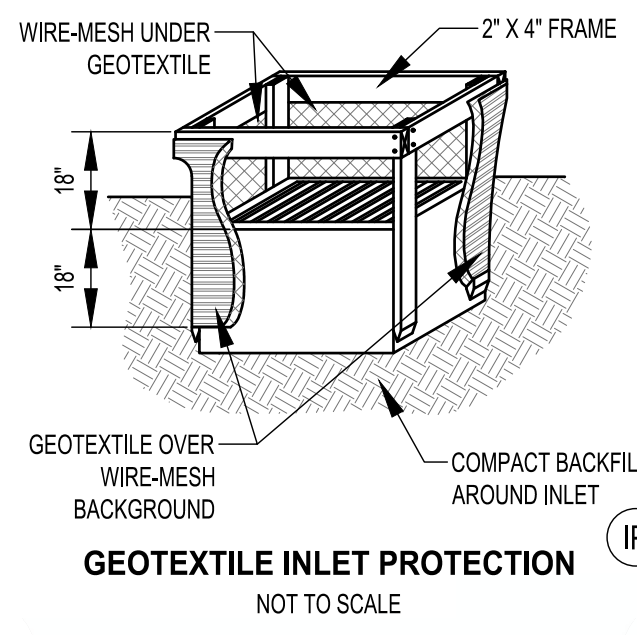

| SEEDING DATES | SPECIES | Lb. / 1,000 SQ.FT. | Lb. / ACRE |
|-------------------|------------------------------------|--------------------|----------------|
| MAR. 1 TO AUG. 15 | OATS | 3 | 128 (4 BUSHEL) |
| | TALL FESCUE | 1 | 40 |
| | ANNUAL RYEGRASS | 1 | 40 |
| | PERENNIAL RYEGRASS | 1 | 40 |
| | TALL FESCUE | 1 | 40 |
| | ANNUAL RYEGRASS | 1 | 40 |
| | ANNUAL RYEGRASS | 1.25 | 55 |
| | PERENNIAL RYEGRASS | 3.25 | 142 |
| | CREeping RED FESCUE | 0.4 | 17 |
| | KENTUCKY BLUEGRASS | 0.4 | 17 |
| AUG. 16 TO NOV. | OATS | 3 | 128 (3 BUSHEL) |
| | TALL FESCUE | 1 | 40 |
| | ANNUAL RYEGRASS | 1 | 40 |
| | RYE | 3 | 112 (2 BUSHEL) |
| | TALL FESCUE | 1 | 40 |
| | ANNUAL RYEGRASS | 1 | 40 |
| | WHEAT | 3 | 120 (2 BUSHEL) |
| | TALL FESCUE | 1 | 40 |
| | ANNUAL RYEGRASS | 1 | 40 |
| NOV. 1 TO FEB. 29 | PERENNIAL RYE | 1 | 40 |
| | TALL FESCUE | 1 | 40 |
| | ANNUAL RYEGRASS | 1 | 40 |
| | USE MULCH ONLY OR DORMANT SEEDING. | | |

TEMPORARY SEEDING TABLE
NOT TO SCALE

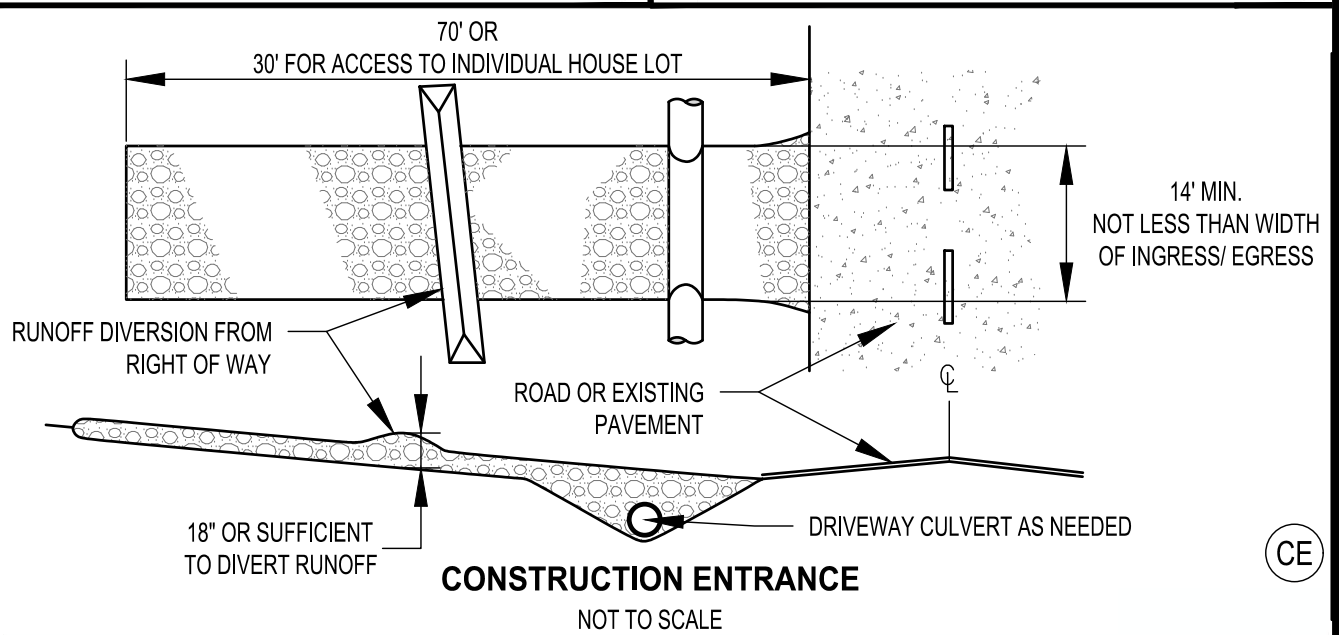
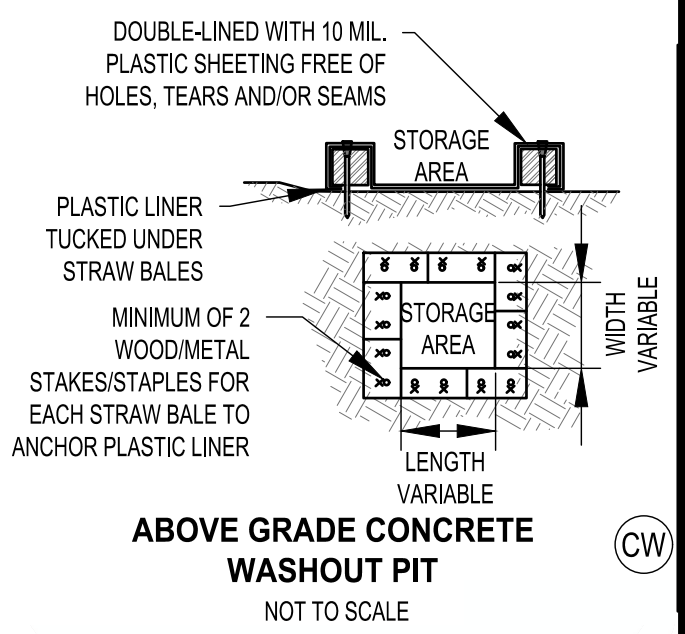
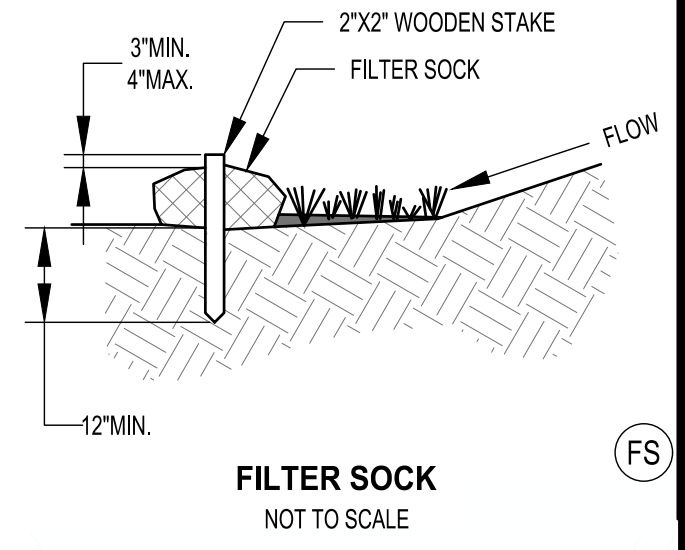

24003-009

Barrington CONSULTING GROUP, INC. Civil Engineers - Surveyors - Land Planners
9114 TYLER BLVD., MENTOR, OHIO 44060 440.215.1260 WWW.BarringtonCGI.com

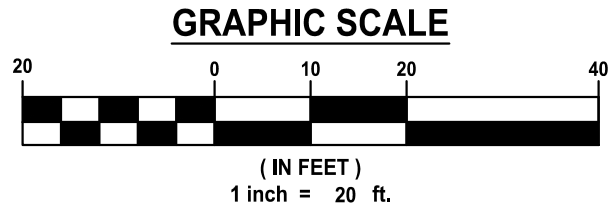
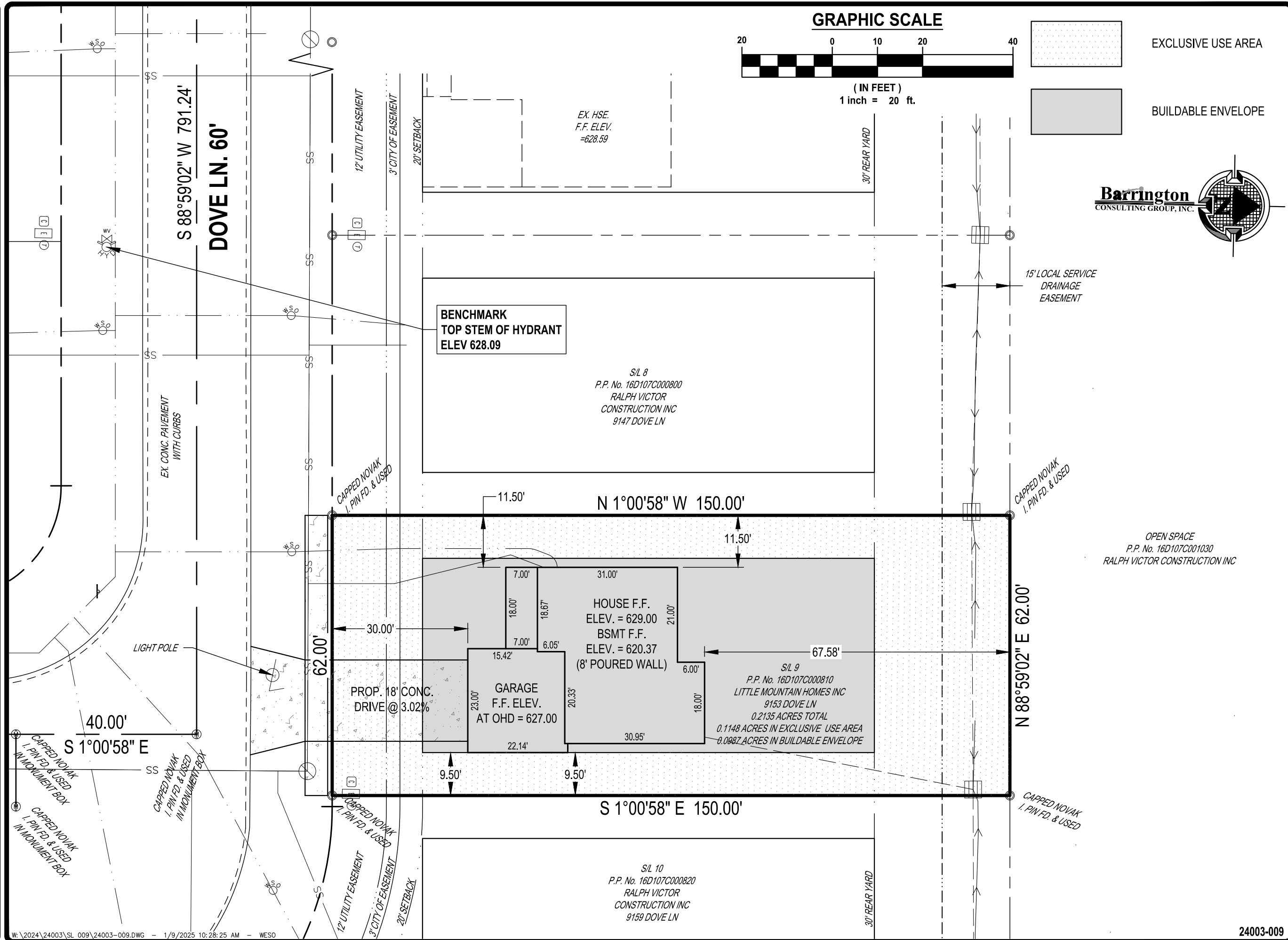

EXCLUSIVE USE AREA

BUILDABLE ENVELOPE



| DATE | REVISIONS | BY |
|------|-----------|----|
| | | |
| | | |
| | | |

Barrington
 CONSULTING GROUP, INC.
 9114 TYLER BLVD., MENTOR, OHIO 44060
 PHONE 440.205.1260
 www.BarringtonCGI.com



LAYOUT PLAN
 9153 DOVE LN., MENTOR, OHIO 44060
 S/L 9 GLENBROOK ESTATES SUBDIVISION VOL. 72 PG. 30
 LITTLE MOUNTAIN HOMES, INC.

| | |
|---------|-----------|
| DRAWN | WSO |
| CHECKED | DWN |
| DATE | 1/7/25 |
| SCALE | 1" = 20' |
| JOB NO. | 24003-009 |
| SHEET | 3 |

| DATE | REVISIONS | BY |
|------|-----------|----|
| | | |
| | | |
| | | |
| | | |

Barrington
CONSULTING GROUP, INC.
9114 TYLER BLVD., MENTOR, OHIO 44060
PHONE 440.215.1260
www.BarringtonCGI.com

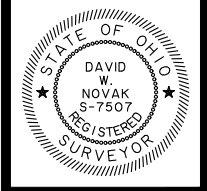

SITE PLAN
9153 DOVE LN., MENTOR, OHIO 44060
S/L 9 GLENBROOK ESTATES SUBDIVISION VOL. 72 PG. 30
LITTLE MOUNTAIN HOME, INC.

DRAWN WSO
CHECKED DWN
DATE 1/7/25
SCALE 1" = 20'
JOB NO. 24003-009
SHEET

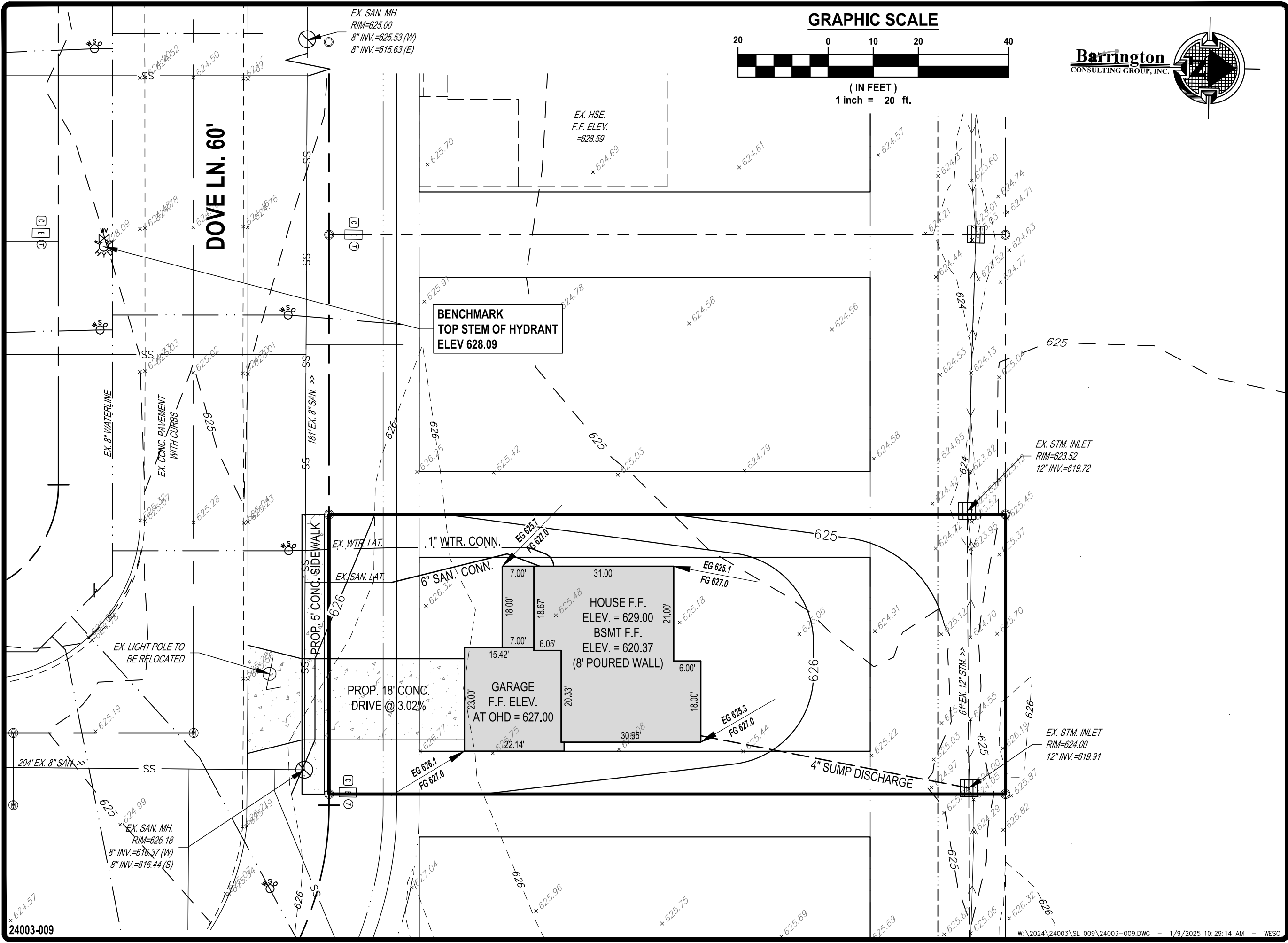

Barrington CONSULTING GROUP, INC. Civil Engineers - Surveyors - Land Planners
9114 TYLER BLVD., MENTOR, OHIO 44060 440.215.1260 WWW.BarringtonCGI.com

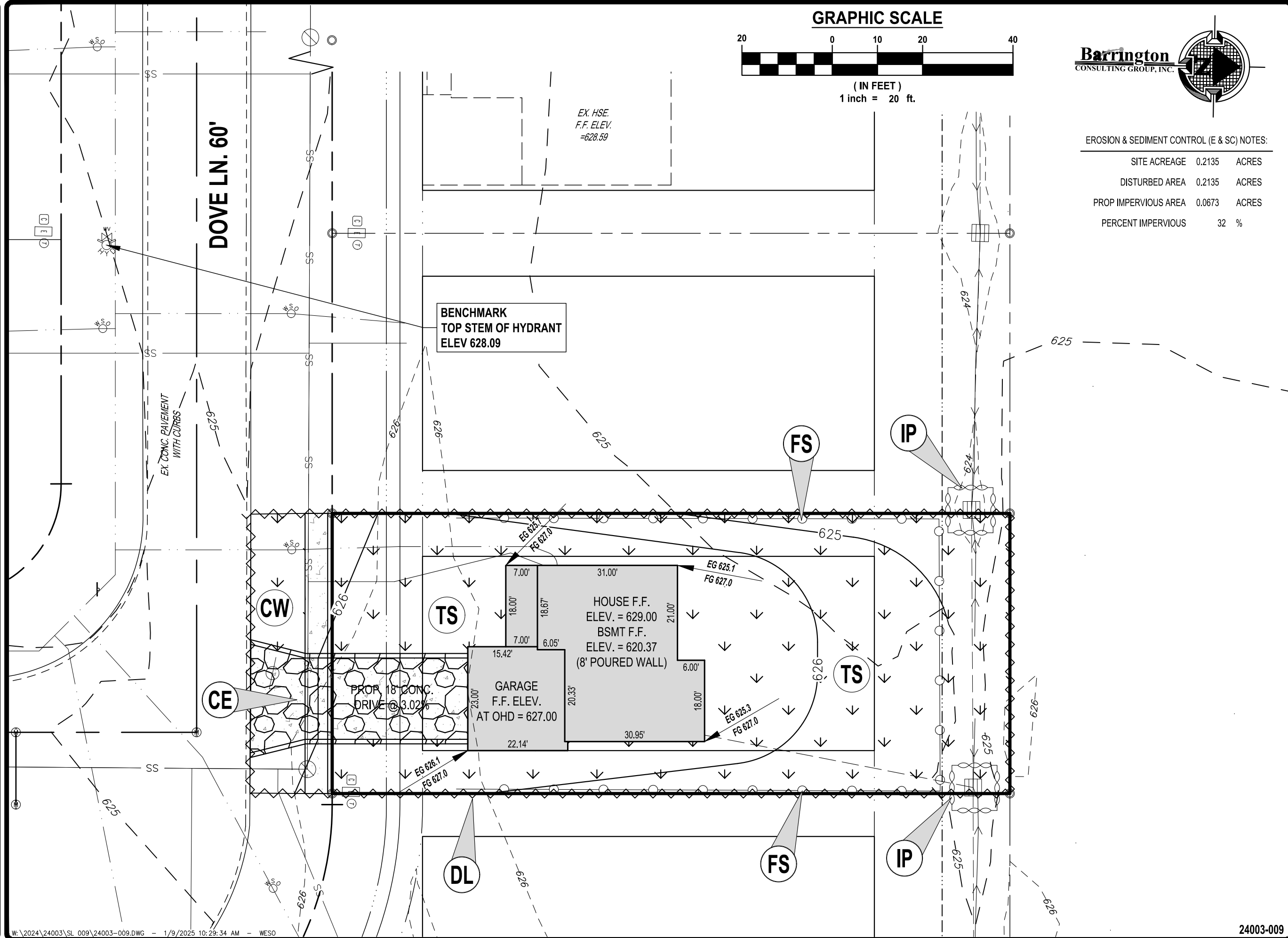

GRAPHIC SCALE

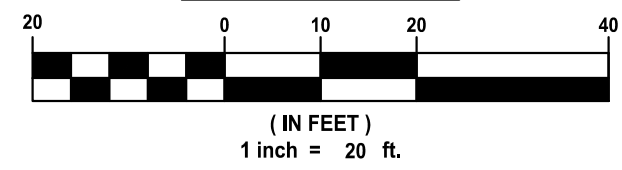

EROSION & SEDIMENT CONTROL (E & SC) NOTES:

| | | |
|----------------------|--------|-------|
| SITE ACREAGE | 0.2135 | ACRES |
| DISTURBED AREA | 0.2135 | ACRES |
| PROP IMPERVIOUS AREA | 0.0673 | ACRES |
| PERCENT IMPERVIOUS | 32 | % |

| DATE | REVISIONS | BY |
|------|-----------|----|
| | | |
| | | |
| | | |

Barrington
 CONSULTING GROUP, INC.
 9114 TYLER BLVD., MENTOR, OHIO 44060
 PHONE 440.205.1260
 www.BarringtonCGI.com



E & SC PLAN
 9153 DOVE LN., MENTOR, OHIO 44060
 S/L 9 GLENBROOK ESTATES SUBDIVISION VOL. 72 PG. 30
 LITTLE MOUNTAIN HOMES, INC.

| | |
|---------|-----------|
| DRAWN | WSO |
| CHECKED | DWN |
| DATE | 1/7/25 |
| SCALE | 1" = 20' |
| JOB NO. | 24003-009 |
| SHEET | 5 |